

## Twin 40G/s 2R Optical Regenerator

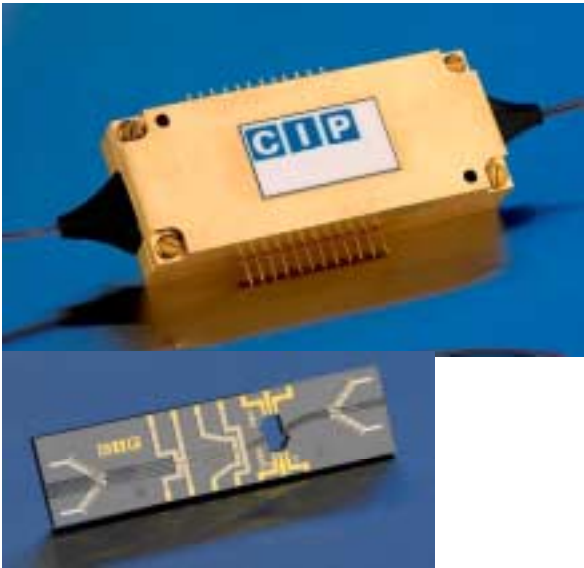

### Features

- 40Gb/s operation
- Low switching energies (<100fJ per pulse per SOA)
- Low insertion loss (<5dB fibre to fibre)
- High output power (>0dBm)
- C Band operation (1530-1565nm)
- Single stage 2R regeneration for 2 independent data channels
- Dual stage regeneration for a single data channel

### Applications

- Transmission impairment mitigation
- Wavelength conversion
- Cascaded two stage 2R regeneration with or without wavelength conversion
- Optical logic element

### Description

CIP Technologies twin optical regenerator provides the capability for 2R regeneration (Re-shaping and Re-amplifying) of degraded data at rates of up to 40Gb/s and is bit rate and protocol transparent. The package houses two 40Gb/s regenerators in the same footprint as that previously required for a single regenerator device (40G-2R-ORP) and can regenerate two independent channels simultaneously. In addition, the two regenerators can be looped back to provide cascaded two stage regeneration and allow the output wavelength to be the same as the input wavelength.

The device can support applications in long-haul, metro and access networks. In addition, the device performs a variety of optical logic functions and can be used in optical processing applications.

The optical module is a hybrid integrated device consisting of two planar silica Mach-Zehnder interferometers with a quad array of non-linear SOAs in the interferometer arms. Independent thermo-optic phase shifters are incorporated to allow precise phase control of the interferometers. The module includes Peltier and thermistor for temperature control, electrical pins for SOA bias currents and phase shifters, 8 way fibre ribbon input (8x FC/APC connectors), and 4 way fibre ribbon output (4x FC/APC connectors). The package dimensions are 90mm x 31mm x 14mm.

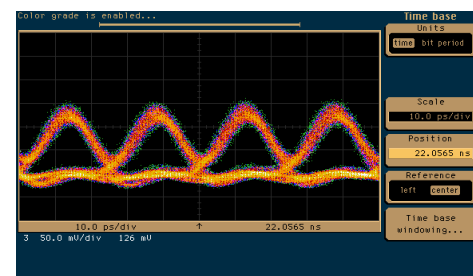
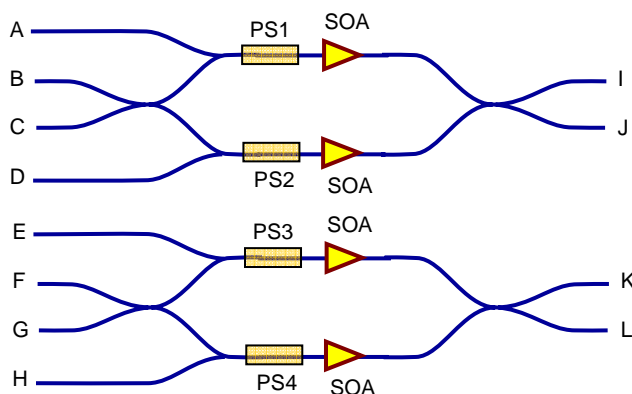

### Operation

Measured eye diagram at 40Gb/s showing operation of the 2R regenerator as a wavelength converter. Device was operating in push-pull mode with co-propagating clock and data with a 12.5ps switching window. Average switching powers at 40Gb/s were 3dBm



**Absolute maximum ratings**

Parameter	Rating	Unit
SOA bias current (per SOA)	400	mA
Average switching data power	+13	dBm
Average CW wavelength power	+13	dBm
Peltier Current	2.5	A
Operating Temperature	30	°C

**Ordering Information— Part Number 40G-2R2-ORP**

For custom products please contact CIP Sales on +44 1473 663210 or e-mail sales@ciphotonics.com. For details of your local agent, visit www.ciphotonics.com

**Pin out and Dimensions**

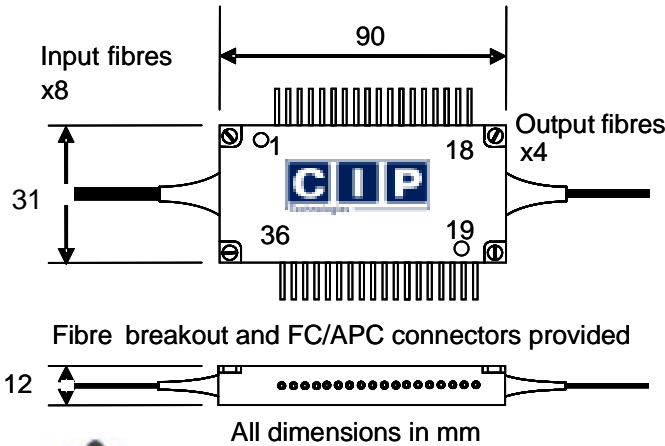

1	Thermistor	19	NC
2	Thermistor	20	NC
3	PS2	21	NC
4	PS1	22	NC
5	PS1	23	NC
6	PS2	24	NC
7	NC	25	SOA 4 (+ve)
8	NC	26	SOA 3&4 (-ve)
9	NC	27	SOA 3 (+ve)
10	SOA 1 (+ve)	28	NC
11	SOA 1&2 (-ve)	29	NC
12	SOA 2 (+ve)	30	NC
13	NC	31	PS3
14	NC	32	PS4
15	NC	33	PS4
16	NC	34	PS3
17	NC	35	Peltier (-ve)
18	NC	36	Peltier (+ve)



Pin#1 is marked with a milled line on side of package (under pin#1)

**Phase Shifters**

The resistance of all the phase shifters is approx 100 ohms. The phase shifters are resistive heaters and should be powered from a voltage source. The current applied to each phase shifter should not exceed 150mA. Each phase shifter is electrically isolated

CIP Technologies is the trading name of The Centre for Integrated Photonics Ltd  
Registered Office - Phoenix House, Adastral Park, Martlesham Heath, Ipswich, Suffolk IP5 3RE  
Registered in England No: 4905488  
VAT Reg No: 824 6260 36 GB



CIP reserves the right to make changes in the design, specifications and other information at any time, and without prior notice. The information contained within the Data Sheet is believed to be accurate. However, no responsibility is assumed for possible inaccuracy or omission. Any information contained herein shall legally bind CIP only if it is specifically incorporated in the terms and conditions of a sales agreement.

Parts of this product are manufactured under one or more of the following patents licensed from British Telecommunications PLC :  
European 143000;384764;416879;531377;890129;156566;227783;218344;279680;261943;390614;174729;228435;228435;242084;245085;746887;767923;830721;1181591;93527.3;1183561;170457;225015;247834;292328;320305;537237;624257;647327;94905188.2;691044;772924;782713;822425;822426;813761;97900375.3;97908417.5;97908417.5;865124 US 4826295;5426312;5481397;5202897;6008926;4734387;4728628;4935936;4754459;4964134;5242857;53329542;4736164;4817207;4981814;5015964;844929;5852696;6188511;6625371;6571037;959329/09;4744619;4793690;4879761;4969704;4973122;4995100;5216237;5371820;5656507;6075625;6229945;6097512;5719974;5832011;5917636;5841928;5978400;6104852;6052213;5974073;6178280; Canada 297211;1284683;2182591;2193095;2221693;2372581;2372401;2373546;1255485;1244519;1281802;1296887;1293996;2085596;2117682;2280472;2153798;2155528;2185132;2199513;2367133;2212736;2240519;2248042;1268848;2047196;2065247;2082939;2243279;1236554;1228936;1261483;265604;1295722;1332341;2049356; Japan 2837265;2968335;1000942;2134710;2547001;2935415;2140794;2708165;2984365;2018663;1868104;2670519;2128400;2764141;1957418;2664457;2081567;3117708;3404040;3556665;3346570;95-525482;97-525789;97-534136

Parts of this product are manufactured under the following patent licensed from Corning Incorporated : US 6,778,718